

EARTH ELECTRODES GROUNDING CONNECTORS grounding connector

F195052



**WERSJA MATERIAŁOWA:**

hot galvanised steel

**OPIS:**

The grounding connector is installed at the stage of building foundations. The product can be used as a potential equalization point or a point of a lightning protection system. For the material version: hot-dip galvanized steel, the front part is made of acid-resistant stainless steel /OH/, grade 1.4404 (V4A), connection rod is made of hot-dip galvanized steel /OG/. In the case of the material version: stainless steel, both the front part and the connecting rod are made of acid-resistant stainless steel /OH/ in grade 1.4404 (V4A).

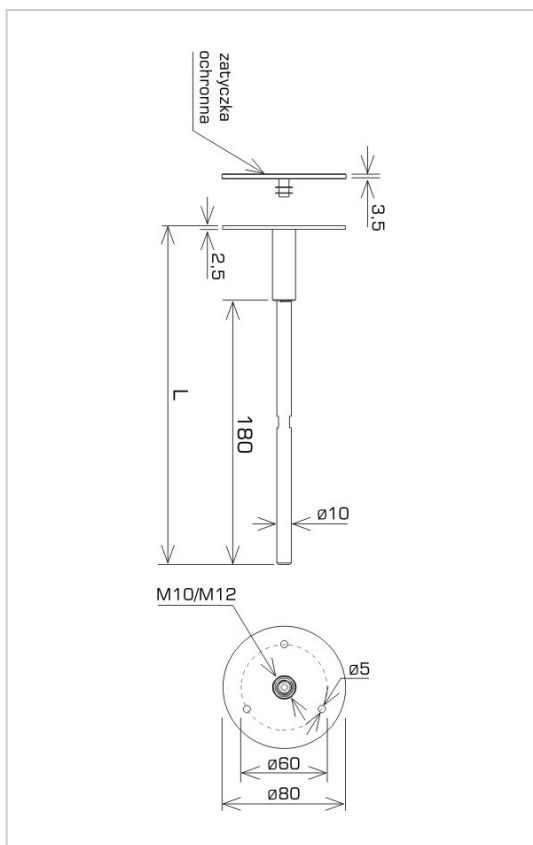

<b>symbol</b> typ	<b>F195052</b> AN-52K/OG/
<b>L(mm)</b>	235
<b>wersja materiałowa</b>	hot galvanised steel



AN-KOM 2 Sp. z o.o.  
 Inwałd, ul. ks. Władysława  
 Bukowińskiego 15  
 34-120 Andrychów



an-kom.pl  
 sales@an-kom.pl



tel./fax  
 +48 605 527 132