

Terminal strips **SCREW CLAMPS** screw clamp

P919296

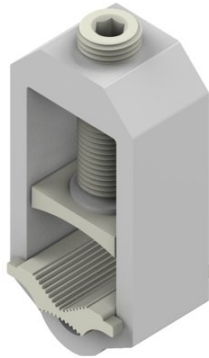

WERSJA MATERIAŁOWA:

aluminium

OPIS:

Screw clamp for connecting wires in electrical switchboards.

The product complies with the standard:

PN-EN - 60947-7-1:2012

PN-EN - 60947-1:2010

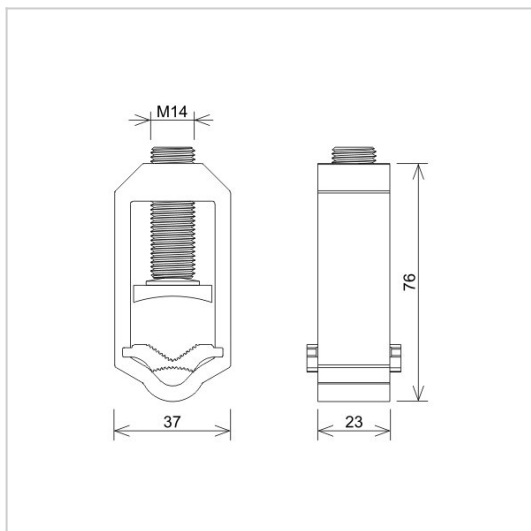

symbol	P919296
typ	ZVK2-300
sm	70 - 120
se	95 - 300
rm	50 - 120
re	70 - 150
wersja materiałowa	aluminium



AN-KOM 2 Sp. z o.o.
Inwałd, ul. ks. Władysława
Bukowińskiego 15
34-120 Andrychów



an-kom.pl
sales@an-kom.pl



tel./fax
+48 605 527 132