

Terminal strips **SCREW CLAMPS** screw clamp

**P919304**

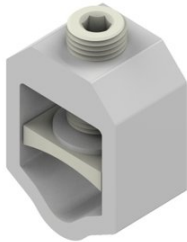

**WERSJA MATERIAŁOWA:**

aluminium

**OPIS:**

Screw clamp for connecting wires in electrical switchboards.

**The product complies with the standard:**

PN-EN - 60947-7-1:2012

PN-EN - 60947-1:2010

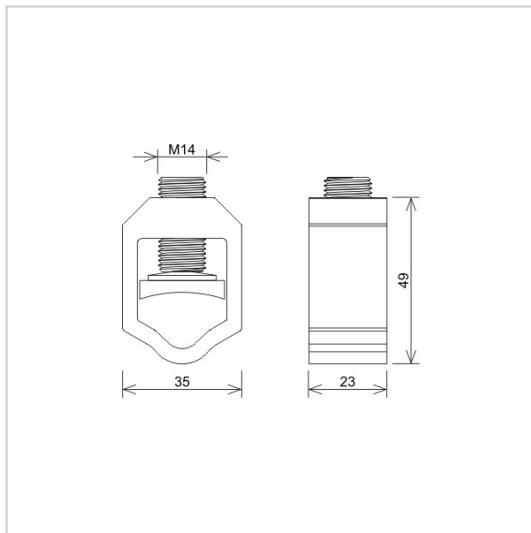

<b>symbol</b>	<b>P919304</b>
typ	ZVK-300
<b>sm</b>	70 - 240
<b>se</b>	95 - 300
<b>rm</b>	50 - 120
<b>re</b>	70 - 150
<b>wersja materiałowa</b>	aluminium



AN-KOM 2 Sp. z o.o.  
 Inwałd, ul. ks. Władysława  
 Bukowińskiego 15  
 34-120 Andrychów



an-kom.pl  
 sales@an-kom.pl



tel./fax  
 +48 605 527 132